

1) 100g, 8g, 50g

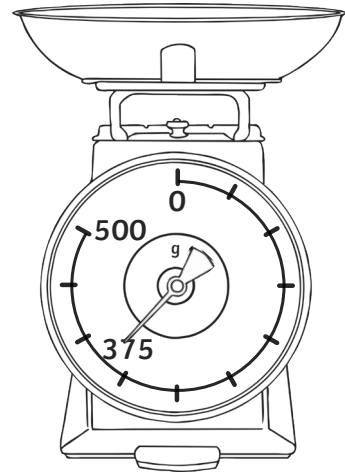
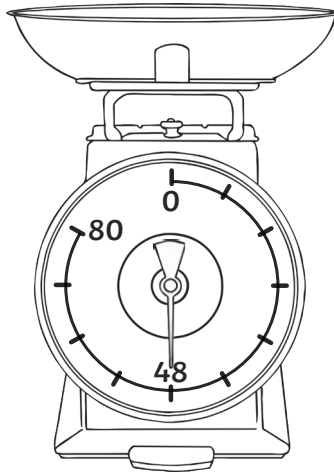
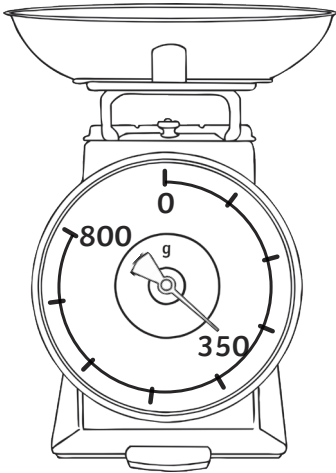

1) 100g, 50g, 10g

2) Third set

3) Ali is incorrect. Each interval is worth 50g, so the answer should be 375g.



1) 1 plum = 50g

1 banana = 75g

1 strawberry = 20g

2) Accept any correct combination with a mass of 300g, for example 2 bananas, 1 plum and 5 strawberries.

